

# The UniForce Technical Manual

A range of standardised design documents  
developed to simplify the process of making correct  
provision for smoke control



## UNIFORCE TECHNICAL MANUAL

# Contents

## 01

### System Specifications

Understand the system specifications of UniForce and download them in Word format to insert into the employer's requirements and specification.

## 02

### Cause & Effect

Read a detailed breakdown of the System Cause and Effect for our UniForce Mechanical Smoke Ventilation System.

## 03

### Electrical Wiring

Check to see what allowances need to be made for the system and download the electrical diagrams to include into your specification documents.

## 04

### System Components

View and download detailed product datasheets and declarations of performance for all UniForce system components.

## OVERVIEW

# System Scope

The UniForce system is capable of protecting the common escape routes for both means of escape and firefighting activities by maintaining tenable conditions within the corridor for firefighting access, based on the following criteria:

- Mechanical extract systems with inlet via stairwell, natural shaft or AOV
- Maximum number of protected lobbies: 20
- Maximum escape travel: 30m
- Relationship between shaft and replacement air source to be in accordance with the approved layout drawings.

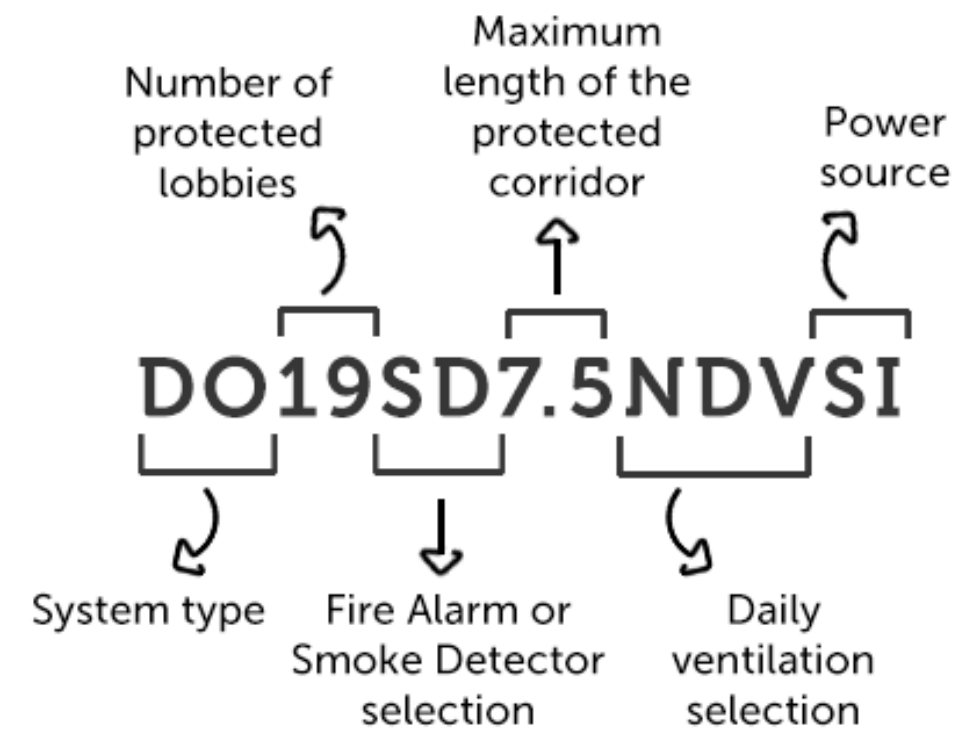

UniForce System Code Explanation

OVERVIEW

# Corridor Layouts

This system manual contains information for the UniForce Single Shaft System that is suitable for the corridor and lobby layouts you can see on these pages.

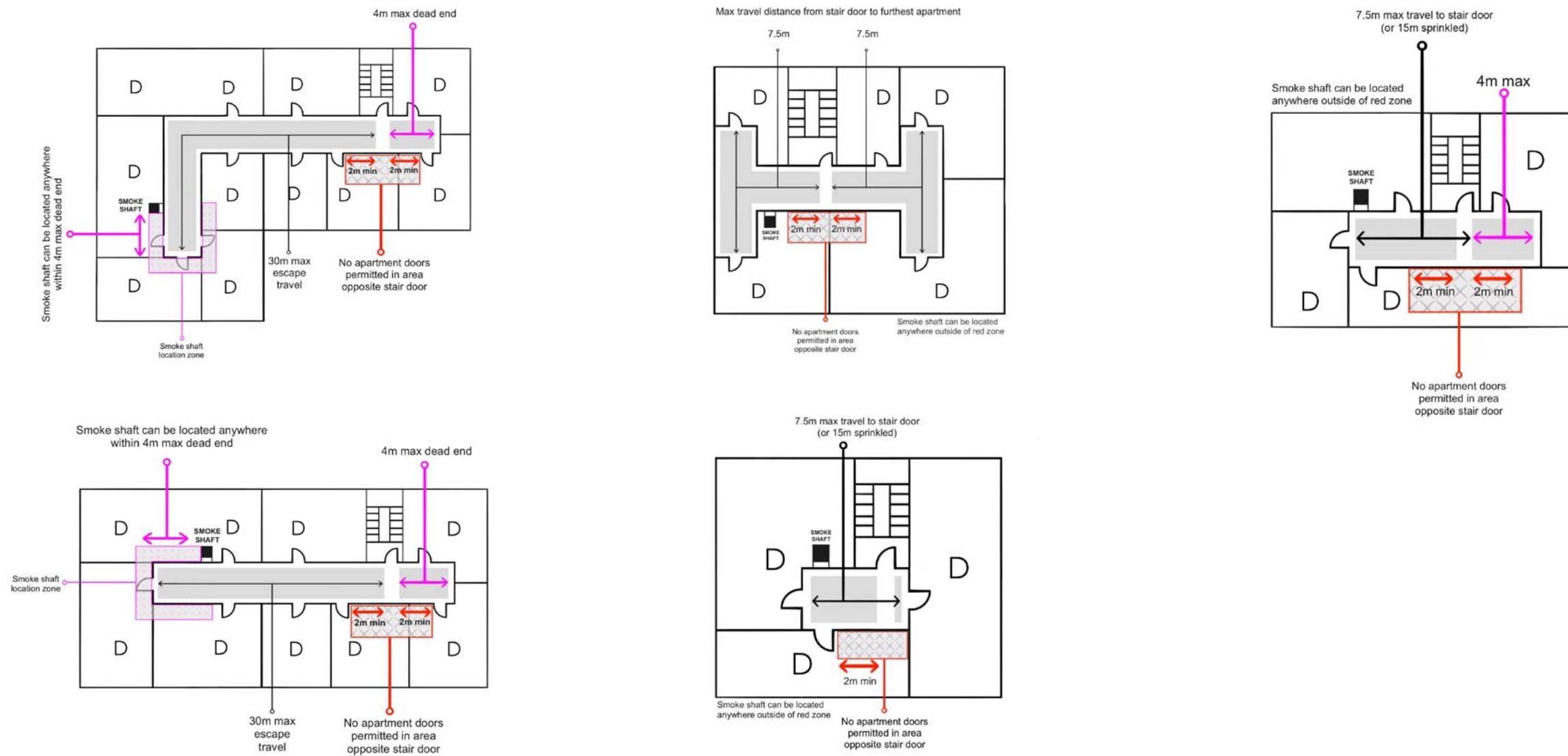

OVERVIEW

# Corridor Layouts

This system manual contains information for the UniForce Single Shaft System that is suitable for the corridor and lobby layouts you can see on these pages.

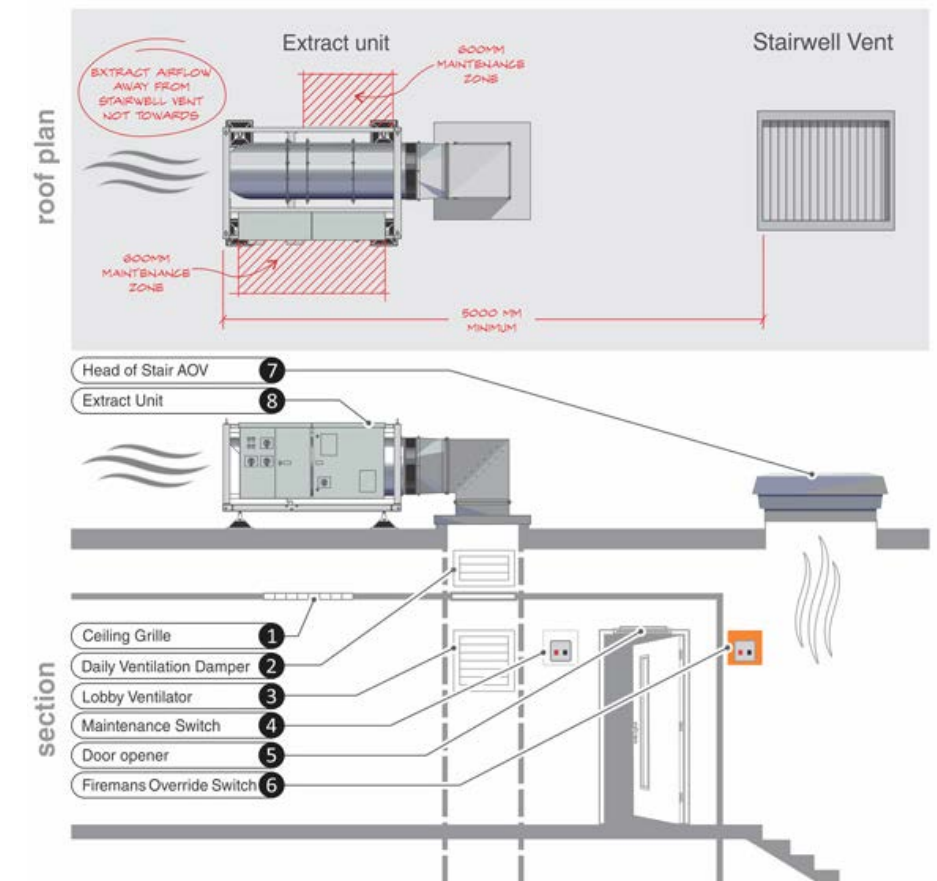
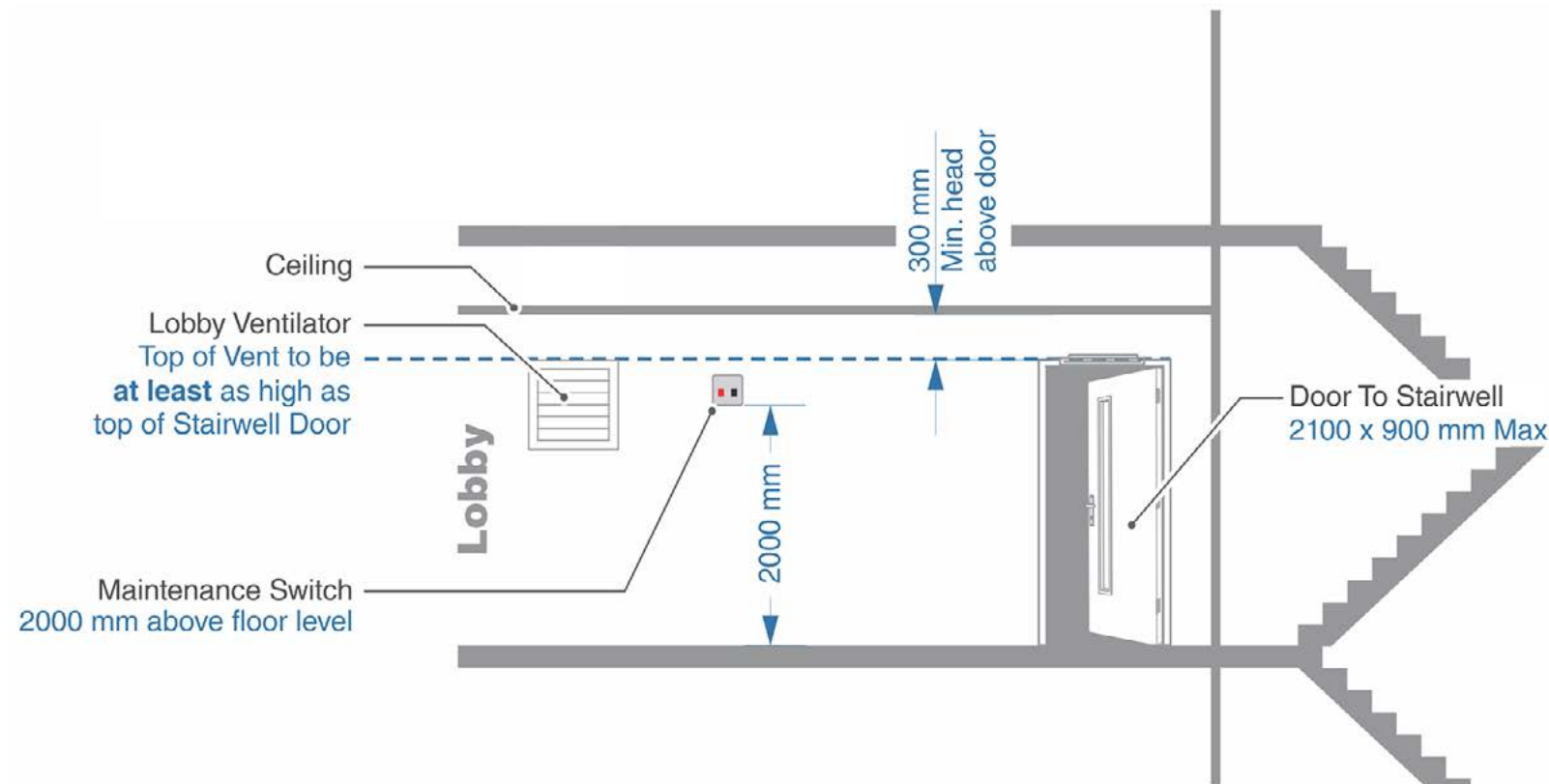

## OVERVIEW

# System Specifications

UniForce is a universal smoke control solution for high rise residential buildings and provides the equivalent performance to the BRE shaft so meeting the requirements of the Building Regulations Approved Document B. In addition, the system has been designed to provide safe conditions for escape and firefighting in buildings with extended travel distances subject to the building layout meeting one of the approved templates.

The system exhausts smoke from the common lobbies through a builder's work shaft using a roof mounted extract unit. Replacement air is drawn from the stairwell ventilator through the stair lobby door.

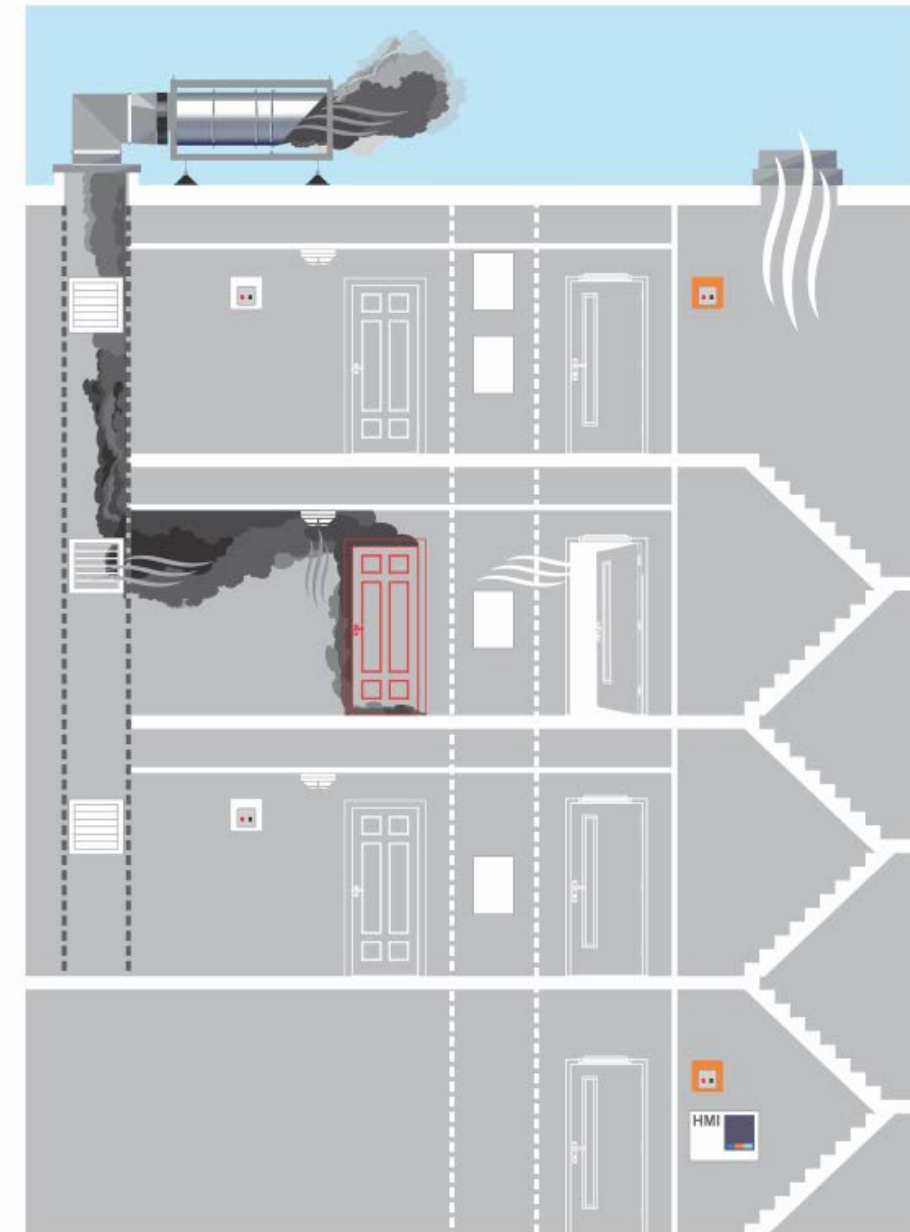

UniForce System Schematic

## OVERVIEW

# System Specifications

The system is dual purpose and can be used to exhaust heat from the common lobby for general ventilation purposes through dedicated daily ventilation dampers located in the smoke shaft above the ceiling. The system performance has been verified through an extensive CFD modelling programme and a full suite of design documents is available.



## System Specifications for Smoke Control

[Download](#)

## System Specifications with Daily Ventilation

[Download](#)

## Features and benefits

- The system includes firefighting tenability criteria and operates automatically as recommended by the National Fire Chiefs Council in the Smoke Control Association Guidance on Smoke Control to Common Escape Routes in Apartment Buildings
- The UniForce system is supplied with the Eyeball remote monitoring and test facility built in. This allows for regular testing to be carried out automatically to ensure the system remains operational. This can be vital in residential buildings without an on-site maintenance presence.
- Open protocol third party assessed software enabling seamless communication with other systems and ongoing maintenance from a network of approved installers.

## SMOKE CONTROL



# System Cause & Effect

1. The smoke control system is activated by the AOV smoke detection/landlords fire alarm system:
2. The 0.6m<sup>2</sup> smoke shaft vent in the corridor sensing smoke opens.
3. The 1.0m<sup>2</sup> AOV at the head of the stairwell opens.
4. The Roof Mounted Extract Fan will operate and ramp up to full speed. Should the run fan fail at any time the standby fan will automatically operate.
5. The door to the stairs is mechanically pushed open 500mm to prevent the corridor from de-pressurising.
6. Important safety features are built into the control system:
  - If the duty and standby fan both fail, the door will be driven closed;
  - If the actuator fails, the fans will run at low speed to prevent corridor over-depressurisation.
7. All other lobby dampers are locked out to prevent them opening and causing a possible 'short circuit' through the smoke shaft.
8. Manual stop/start buttons are contained on the User Interface Panel at the fire service entry point to allow manual firefighter control.
9. The head of stairwell AOV can be manually controlled by either of two manual switches located at top and bottom levels of the staircase.
10. On reset all vents will close and the fans will stop returning the system to standby.



UNIFORCE

# Electrical Wiring

The electrical wiring for the system shall be provided with a CWZ classification in accordance with BS EN 8519 and installed in accordance with the Electrical Wiring Regulations. Cable categories to be in accordance with the single line diagram reference number: SLD-SC-0920-V1.

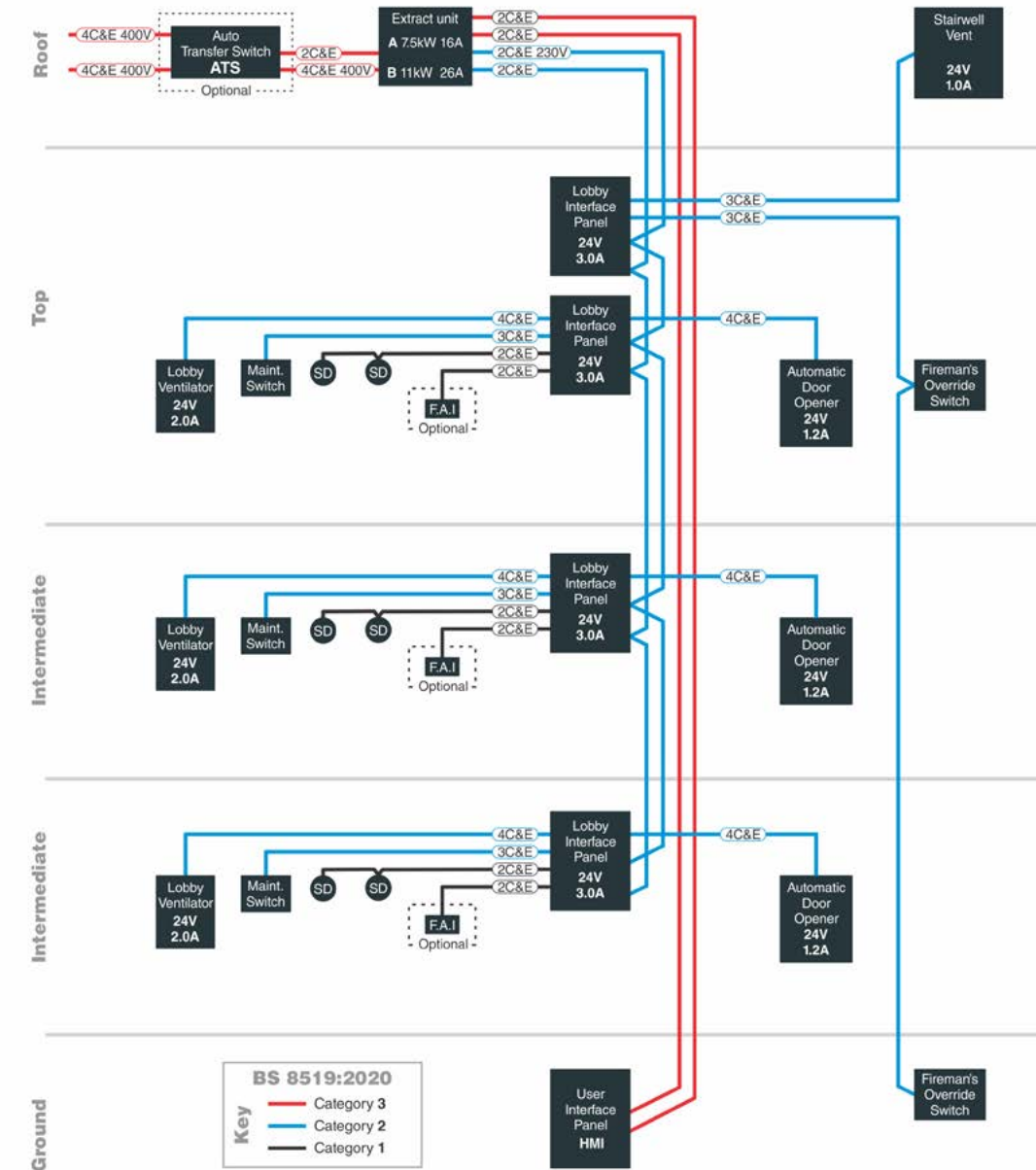
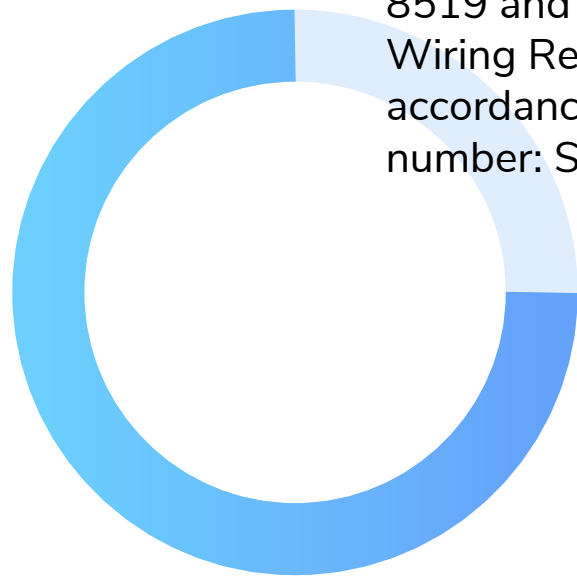

UniForce Single Line Diagram

UNIFORCE

# Download the diagrams

Follow the links below to view our single line diagrams online, as well as download the images to include in your tender documentation.



Single Line Diagram for Smoke Control



Single Line Diagram with Daily Ventilation

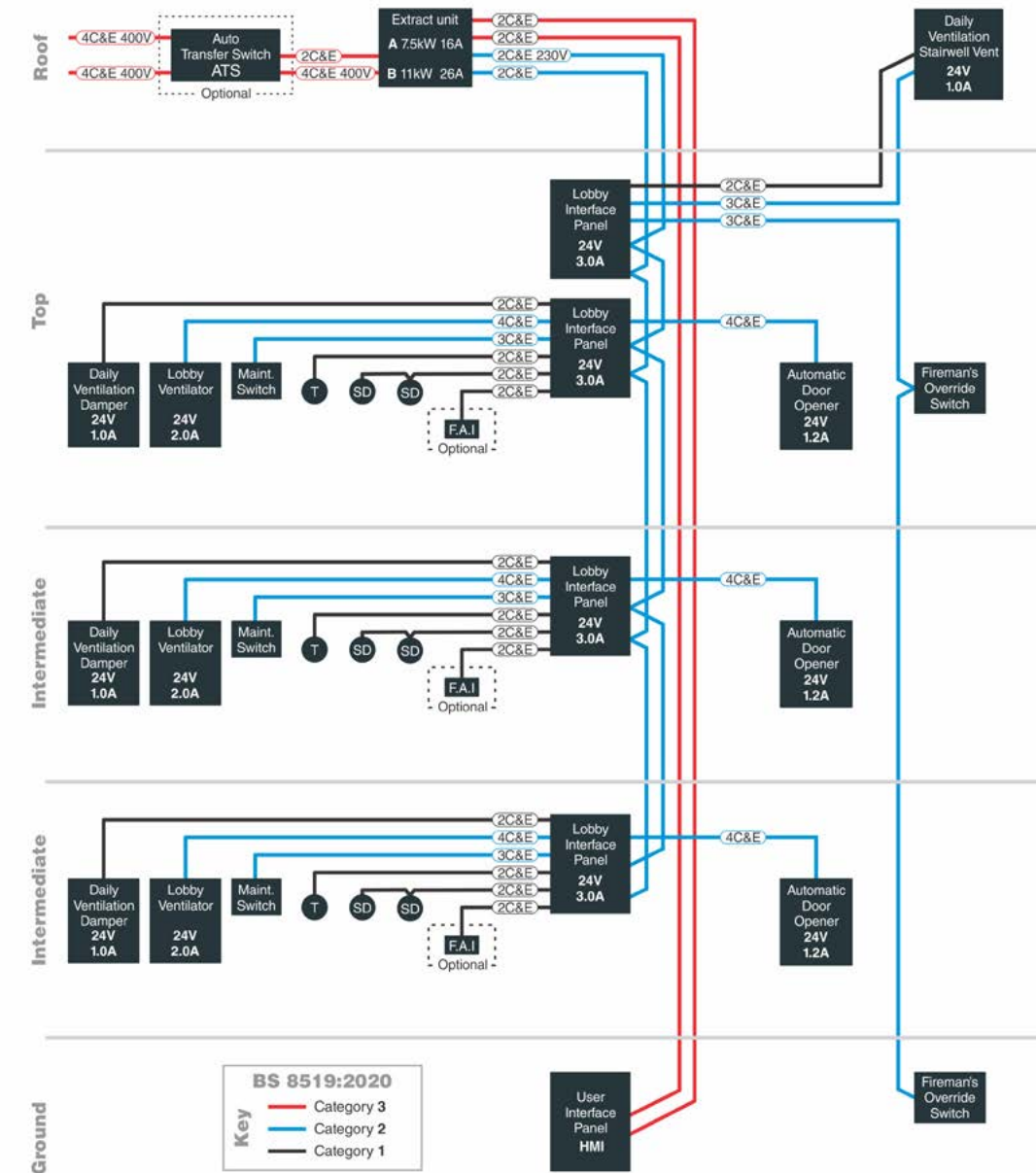

UniForce Single Line Diagram with Daily Ventilation

## SYSTEM COMPONENTS

# Table of Conformance

The table below summarises the standards and tests the product has undergone.

Component	Standard	Classification
Extract Fans	BS EN 12101-3	F300
Ductwork	BS476 Pt 24, EN1366 Pt 1	
Lobby Interface Panels	BS EN 12101-10, ISO 21927	
Lobby Dampers	BS EN 12101-8	E (120 Vew i>o) S C10,000 AA Multi
Daily ventilation dampers	BS EN 55014	EN 13501 E120
Stairwell Ventilators	BS EN12101-2	Re100/B300/WL2122/SL1230
Daily Ventilation Stairwell Ventilators	BS EN12101-2	Re100/B300/WL2100/SL1230
Automatic transfer switches	BS 8519:2010	Tested to BS EN 60947-6-1
Door Openers	BS EN 12101-2	Re1000
Electrical Cabling	BS 8519	Minimum categories: <ul style="list-style-type: none"> <li>•Power and control cables to dampers and ventilators Category 2</li> <li>•Power cables to Fans Category 3</li> <li>•Fireman's override controls Category 3</li> </ul>

## SYSTEM COMPONENTS

# Extract unit

The extract plant is a skid-mounted unit comprising of fans, dampers, and controls designed specifically for smoke shaft applications. Extract fans will be axial high temperature fans manufactured from hot dipped galvanized steel sheet.

- Factory assembled and tested unit
- Compliant with all relevant standards
- Third party tested open protocol software
- Includes monitoring and remote testing facility

[Datasheet](#)[Declaration of Performance](#)

## SYSTEM COMPONENTS

# Control System

The control system will be compliant to BS EN 12101-10, and BS ISO 21927-9 and will be an intelligent PLC based modular control system using a proven fieldbus protocol to interface with hardware. The system will communicate with the HMI user interface and can be interfaced directly with a BMS or other monitoring system over Modbus TCP/IP protocol to provide remote monitoring.

The system will incorporate the **Group SCS Eyeball remote automatic test facility** that will run a comprehensive test sequence at scheduled intervals and issue a compliance report to building management. Our Eyeball self-test system can be added to all Group SCS standard systems to provide automatic testing and reporting.

[Declaration of Performance](#)

## The benefits of Eyeball

- **Scheduled automatic system testing and reporting**
- **Broadband or 3G mobile connectivity**
- **User login for remote testing and diagnostics**
- **Support centre access for remote software diagnostics and updates without a call-out**
- **Secure remote access and data transfer to the cloud**
- **Installed within and powered by the shaft system main control panel**

[Find out more about Eyeball](#)

## SYSTEM COMPONENTS

# User Interface Panel (HMI)

The master user interface panel is a 7" colour touchscreen with function keys. User facilities will allow the operator to access system configuration, maintenance and testing functions and provide Fireman's override facilities through dedicated push buttons.

Dimensions	240 H x 296 W x 96 D (mm)
Weight	2.0 Kg
Power Supply	Maintained 230V AC supply from Fan Panel
Finish	White gloss acrylic-capped ABS
IP Rating	IP42 (indoor use only)
Conformity	CE Marked to low voltage and EMC Directives

[Datasheet](#)
[Declaration of Performance](#)

## SYSTEM COMPONENTS

# Lobby Interface Panel

Model No.	EV-301-MC
Input	230V 50Hz - From Main Control Panel
Output	24V reverse polarity
Max. output current	3.0A
Height	323 mm
Width	300 mm
Depth	86 mm
IP Rating	IP42
Finish	Powder coated - White
Conformity	EN2101.10 ISO21927

[Datasheet](#)
[Declaration of Performance](#)

## SYSTEM COMPONENTS

# Smoke Detector

Detection within the lobby can be by interfaces with the building fire alarm system or dedicated ceiling mounted smoke detectors. Where provided, smoke detectors will be approved to EN54-7-2000. Signals from the smoke detectors are received at the interface units located on each floor.

Type	Photo-Electric Optical
Voltage	8.5-33 VDC
Alarm Current	40mA
Dimensions	97mm Dia. x 130 mm H
Finish	White Polycarbonate
Conformity	EN54

[Datasheet](#)



## SYSTEM COMPONENTS

# Lobby Ventilator

Product Reference	2560 Series
Motor	24V power open / power close
Power Supply	24VDC
Damper Dimensions	W: 790mm x H:1190mm x D:350mm
Free Area	0.6m <sup>2</sup>
Damper blade finish	Matt black RAL
Grille finish	Steel, 15° deflection, PPC RAL 9010
Conformity	CE Marked, Tested in accordance with BS 746:24 for fire exposure of up to 4 hours

[Datasheet](#)[Declaration of Performance](#)

## SYSTEM COMPONENTS

# Stairwell Ventilator

The stair will be ventilated by an automatic opening ventilator (AOV) fully compliant to BS EN12101-2 having a geometric free area of 1.0m<sup>2</sup>.

Voltage	24 V DC
Current	0.6 A
Free Area	1.04m <sup>2</sup> [Geometric]
Aerodynamic Free Area	0.92m <sup>2</sup>
Weight	30Kg
Finish	Mill finish aluminium
U Value	0.67 W/m <sup>2</sup> .K (insulated)
Dimensions	L:1270mm x W:1300mm

[Datasheet](#)[Declaration of Performance](#)

## SYSTEM COMPONENTS

# Automatic Door Opener

The Folding Arm<sup>2</sup> Door Opener is the ideal actuator technology for smoke and heat exhaust supply air doors for keeping the door for the daily use manually flexible.

Voltage	24 volts, reverse polarity
Current	1.2 amps
Force	300 N
Dimensions	340mm L x 115mm H x 58mm D
Weight	3.5 Kg
System Connection	3 core cable directly to zone panel
Conformity	BSEN 12101:2

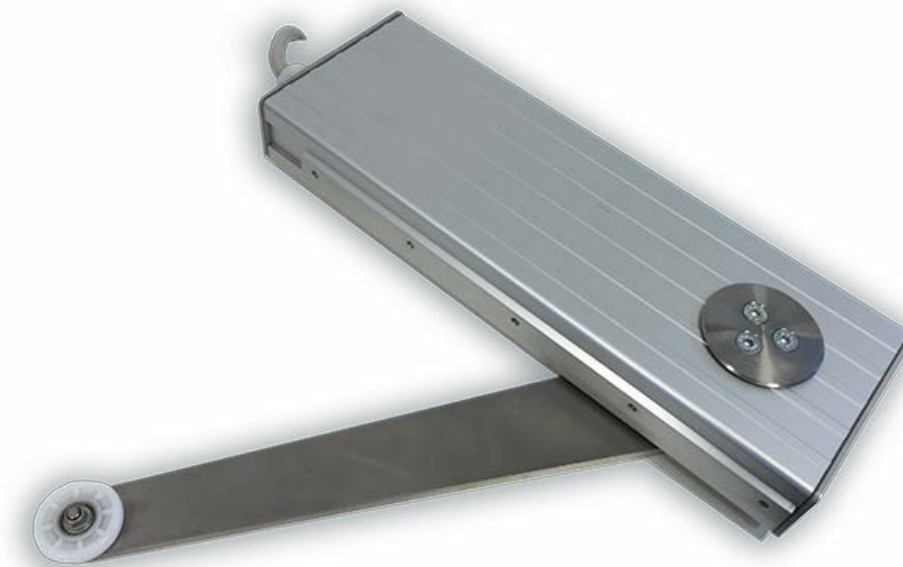
[Datasheet](#)[Declaration of Performance](#)

## SYSTEM COMPONENTS

# Maintenance Switch

Tamper-proof switch for testing and monitoring smoke control systems. Located near lobby ventilator for testing and monitoring purposes.

Dimensions	125 H x 125 W x 35 D (mm)
Finish	Case = ABS, white Hinged lid = ABS, clear

[Datasheet](#)

## SYSTEM COMPONENTS

# Fireman's Override Switch

Local fireman's override switches will be break glass tamperproof type at the highest and lowest floors of the stairwell.

Dimensions	125 H x 125 W x 35 D (mm)
Finish	Case = ABS, orange Hinged lid = ABS, clear

[Datasheet](#)

## SYSTEM COMPONENTS (OPTIONAL)

# Daily Ventilation Lobby Interface Panel

Model No.	EV-301-DV
Input	230V 50Hz - From Main Control Panel
Output	24 Reverse polarity - Smoke Vent 24V Power open/spring close - Daily Vent
Max. output current	3.0 A Smoke Vent, 1.0 A Daily Vent
Height	444 mm
Width	300 mm
Depth	86 mm
IP Rating	IP42
Finish	Powder coated - White
Conformity	EN2101.10 ISO21927

[Datasheet](#)
[Declaration of Performance](#)

## SYSTEM COMPONENTS (OPTIONAL)

# Daily Ventilation Damper

The daily ventilation damper should be located in the smoke shaft behind the false ceiling and should be supplied with a power open/spring close actuator. The damper should be CE marked to EN 15650.

Voltage	24 volts
Current	0.5 amps
Motor Type	Power open/spring close
Opening Dimensions	800 mm W x 200 mm H
Finish	Mill
Conformity	BS EN 55014

[Datasheet](#)[Declaration of Performance](#)

## SYSTEM COMPONENTS (OPTIONAL)

# Daily Ventilation Stairwell Ventilator

The roof louvred Multisky is a natural and smoke ventilator perfect for comfort ventilation or as part of an N-SHEV (Natural, smoke and heat exhaust ventilation) system.

Voltage	24V DC
Current	0.6 amps
Dimensions	L:1290mmx W:2567
Free Area	0.77m <sup>2</sup>
Finish	Mill finished aluminium
Weight	30Kg
Conformity	Certified to EN 12101-2

[Datasheet](#)[Declaration of Performance](#)



## SYSTEM COMPONENTS (OPTIONAL)

# Daily Ventilation Internal Thermostat

Thermostat to provide temperature monitoring of the lobby and corridor spaces.

Dimensions	97H x 96W x 36D mm
Range	8 to 30°C
Connection	2 core to zone panel
Conformity	BS EN 55014

[Datasheet](#)

## UNIFORCE TECHNICAL MANUAL

# Quick Links

View and download the UniForce System Documentation to support the specification process and include in your Tender documents.

## Have a project in mind for UniForce?

Use our online Project Submission Tool to send us your project details and relevant documents.

[Send us your project details](#)

### System Specifications for Smoke Control

[Download](#)

### System Schematic for Smoke Control

[Download](#)

### Single Line Diagram for Smoke Control

[Download](#)

### Elevation Diagram for Smoke Control

[Download](#)

### Technical Submittal for Smoke Control

[Download](#)

### System Specifications with Daily Ventilation

[Download](#)

### System Schematic with Daily Ventilation

[Download](#)

### Single Line Diagram with Daily Ventilation

[Download](#)

### Elevation Diagram with Daily Ventilation

[Download](#)

### Technical Submittal with Daily Ventilation

[Download](#)

### Design Report

[Download](#)

### Roof Equipment Layout

[Download](#)

### BIM/CAD Models

[Download](#)

### CFD Report

[Request Access](#)

### Budget Cost Tool

[Get an estimate](#)